

Measurement of the Acoustic Impedance of Air-Columns

Herbert Jaeger
Department of Physics, Miami University, Oxford, OH

Abstract

Acoustic impedance plays a central role when it comes to describing the propagation of sound waves in pipes of various shapes, thus it is desirable to perform impedance measurements to characterize an acoustic system. A simple acoustic impedance probe is described that can be used either as lecture demonstration for non-science majors classes or as an undergraduate physics student laboratory experiment.

Resource Type: Instructor notes
Keywords: Resonance; physical acoustics; acoustic impedance;
Related Materials:

J.-P. Dalmont, *Journal of Sound and Vibration* **243**(3), 2001, 427–439.

J.-P. Dalmont, *Journal of Sound and Vibration* **243**(3), 2001, 441–459.

A.H. Benade and M.I. Ibbi, *Journal of the Acoustic Society of America* **81** (4), 1987, 1152–1167.

Introduction

Having had its heydays in the 19th century, physical acoustics is still a topic in many physics curricula. Admittedly, in introductory physics courses only the very basic topics, such as simple resonance and standing waves on strings and in air columns, are discussed briefly. However, many institutions offer courses along the lines of “Physics of Music” for non-science majors in pursuit of fulfilling their science requirement, that go beyond the basics and discuss more advanced topics, including the intricate workings of woodwinds and brass instruments. Out of necessity the approach must be a qualitative one, since the mathematical background of this audience is not sufficient to allow for the solution of complex differential equations and boundary value problems.

The acoustic impedance plays a central role when it comes to describing the propagation of sound waves in pipes of various shapes. The concept of impedance is not terribly hard, but unfortunately it is a complex quantity (both literally and in the more general sense) and quite intractable for the student in a “poets course”, or even some first year physics students.

However, just like its electrical counterpart, the acoustic impedance may be measured straightforwardly with simple equipment usually found in a first-year physics laboratory or a well-equipped physics stock room.

While it is beyond the typical poets-course student to calculate the impedance of a pipe with a flared bell, it turns out to be quite simple to measure it. Comparison with the impedance of a standard cylindrical pipe of the same length allows to see the effect that the flared bell has on the resonances of the air column.

In this way even students who do not have the mathematical sophistication of a senior physics or engineering major can learn to appreciate the subtleties that go into building a real musical instrument from a plain brass pipe, or why one type of trumpet mouthpiece sounds “brighter” than another one.

Here we discuss a simple device to measure the input impedance of a pipe or a musical instrument, a so-called “impedance probe”. The impedance probe consists of components that can be easily and inexpensively obtained from any mail order electronics parts company such as *Mouser* or *Jameco*, and assembled with tools and parts available at your local hardware store.

Acoustic Impedance

Acoustic impedance is in concept similar to its electrical counterpart and quantifies the tendency of an acoustic system to resist air flow. However, for acoustic systems several flavors of impedances exist. The *acoustic impedance* is defined as the complex ratio of the pressure difference across a section of pipe over the volume flow rate through it, or

$$z_a = \frac{p}{U} \quad (1)$$

The *specific acoustic impedance* is defined as the complex ratio of the pressure difference across a section of pipe over the particle flow rate through it, or

$$Z_s = \frac{p}{u}$$

The volume flow rate is related to the particle velocity u as $U = uS$, with S the cross sectional area of the air flow, so that

$$Z_s = z_a S$$

Newton's 2nd Law for a Packet of Air

Consider a small packet of air of cross section S and length Δx . The pressure difference across its length Δx is $\frac{\partial p}{\partial x} \Delta x$, resulting in a net force $F_{net} = -\frac{\partial p}{\partial x} \Delta x S$ on the packet of air. The resulting acceleration of the mass m of the packet of air is $ma = \rho S \Delta x \frac{\partial u}{\partial t}$, and the relation between pressure and particle velocity is

$$-\frac{\partial p}{\partial x} = \rho \frac{\partial u}{\partial t}. \quad (2)$$

Plane Waves in Air

The acoustic pressure of a plane wave has the form $p(x,t) = Ae^{-i(kx-\omega t)}$, with the wave number $k = \frac{2\pi}{\lambda}$ and the angular frequency $\omega = 2\pi f$. Using Newton's 2nd law (2) and integrating to obtain an expression for $u(x,t)$

$$u(x,t) = \frac{1}{c\rho} Ae^{-i(kx-\omega t)}$$

allows to calculate what is known as the characteristic impedance of air

$$z_o = \frac{p(x,t)}{u(x,t)} = c\rho .$$

For air at 20°C $z_o = 413.2 \frac{Ns}{m^3}$.

Plane Waves in a Pipe of Constant Cross Section S

A plane wave propagating in an infinitely long pipe has the same form

$p(x,t) = Ae^{-i(kx-\omega t)}$, as there is no reflected wave to consider. The characteristic impedance of the pipe is then

$$Z_o = \frac{p(x,t)}{U(x,t)} = \frac{c\rho}{S}$$

Note that the characteristic impedance of the pipe is inversely proportional to the pipe cross section, very much like the electric specific resistance of a wire.

Plane waves in a pipe of finite length have a component of the wave reflected from the far end and thus are of the form

$$p(x,t) = (Ae^{-ikx} + Be^{ikx})e^{i\omega t} .$$

As above, we use Newton's 2nd law and integrate to obtain

$$U(x,t) = \frac{S}{c\rho} (Ae^{-ikx} - Be^{ikx})e^{i\omega t} ,$$

and the acoustic impedance at $x=L$, the far end of the pipe, is

$$z_a = \frac{p(L,t)}{U(L,t)} = Z_o \frac{Ae^{-ikL} + Be^{ikL}}{Ae^{-ikL} - Be^{ikL}} .$$

The impedance at $x=L$ must match the impedance of the "load", Z_L ,

$$Z_o \frac{Ae^{-ikL} + Be^{ikL}}{Ae^{-ikL} - Be^{ikL}} = Z_L$$

and this results in a condition for the ratio of B/A

$$\frac{B}{A} = e^{-i2kL} Z_o \frac{Z_L - Z_o}{Z_L + Z_o} .$$

The impedance at $x=0$, the input impedance Z_{in} is

$$Z_{in} = \frac{p(0,t)}{U(0,t)} = Z_o \frac{A+B}{A-B}$$

and using the expression for B/A we have the input impedance of a cylindrical pipe of length L as

$$Z_{in} = Z_o \frac{Z_L + iZ_o \tan(kL)}{Z_o + iZ_L \tan(kL)} \quad (3)$$

Resonance and Input Impedance

To understand the meaning of the input impedance, let's consider a pipe open at both ends. To good approximation the far open end corresponds to $Z_L = 0$, and the open end at $x = 0$ means we have $Z_{in} = 0$. The expression for Z_{in} of Eq. 3 then becomes the following condition $0 = iZ_o \tan(kL)$, which is satisfied by the zeros of $\tan(kL)$, i.e. $kL = n\pi$ with $n=1, 2, 3, \dots$

Expressing k in terms of the frequency $k = \frac{\omega}{c} = \frac{2\pi f}{c}$ we have $\frac{2\pi f}{c}L = n\pi$ or $f = n \frac{c}{2L}$.

These are the resonances of an open-open cylindrical pipe, i.e. the frequencies for which we have the formation of a standing wave in the pipe.

A pipe open at the far end ($Z_L = 0$) but closed at the other end ($Z_{in} \rightarrow \infty$) results in the condition $iZ_o \tan(kL) \rightarrow \infty$ or $\cot(kL) = 0$, which is satisfied by $kL = n \frac{\pi}{2}$ with

$n = \text{odd integers}$. In terms of the frequency we get $f = n \frac{c}{4L}$ with $n = 1, 3, 5, \dots$

Figure 1 shows a plot of the magnitude of the input impedance for a 69-cm long pipe with both ends open. This is an idealized case as we have ignored losses on the pipe walls. If losses are included, the impedance is damped, as shown in Fig. 2.

The resonance frequencies for the open-open pipe are the minima of the input impedance, while the resonance frequencies for the pipe closed at one end are the maxima of the impedance curves.

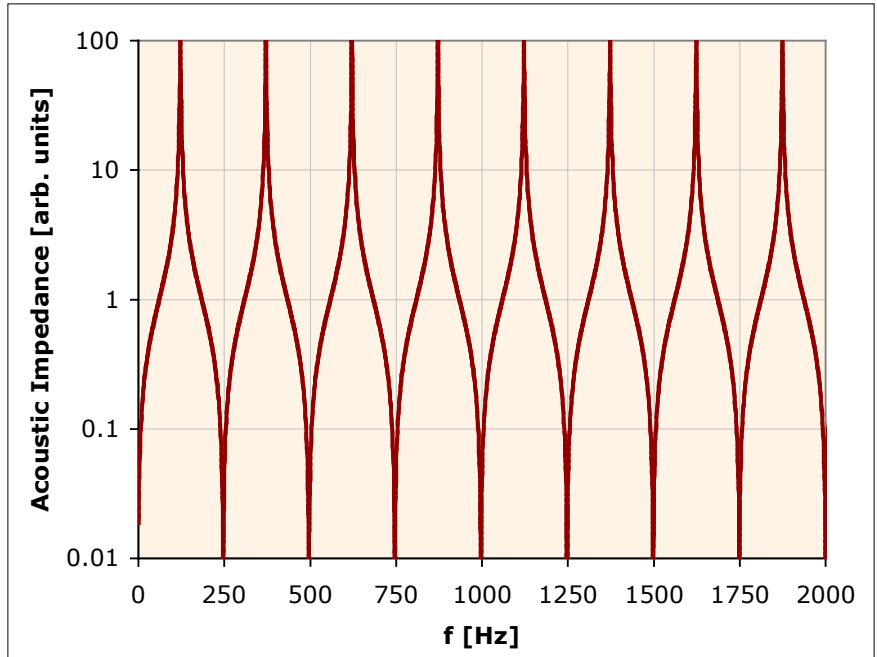

Fig. 1: Input impedance of a loss-less pipe of $L = 69$ cm open at both ends.

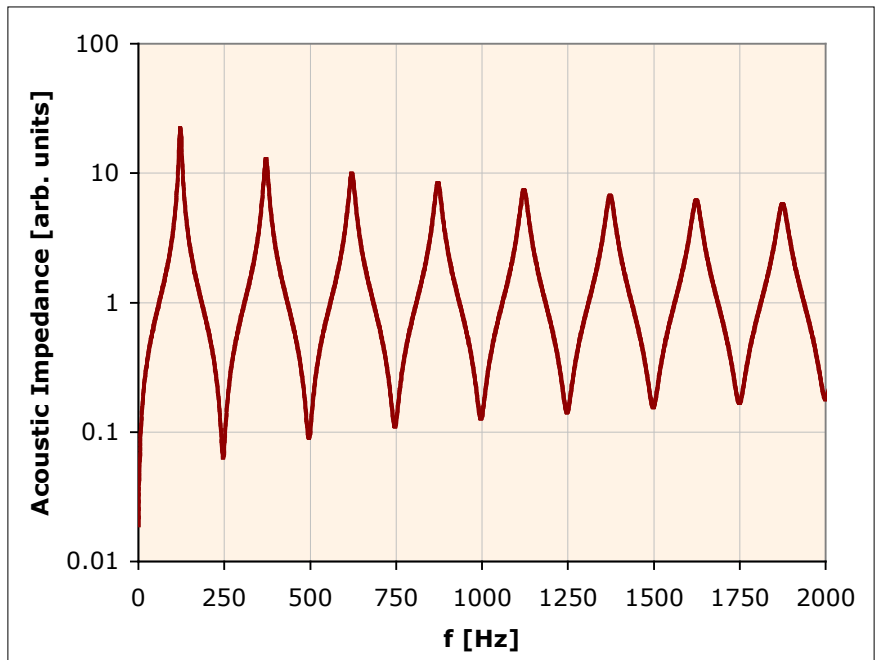

Fig. 2: Input impedance of a pipe of $L = 69$ cm open at both ends. Wall-losses are included and result in a "damping" of the impedance curve. Details about including losses can be found in N. H. Fletcher and T. D. Rossing, *The Physics of Musical Instruments*, 2nd Edition, Springer (1998).

Measurement of Acoustic Impedance

A review of methods to measure acoustic impedance is given by J.-P. Dalmont, *Journal of Sound and Vibration* **243**(3), 2001, 427–439; *Journal of Sound and Vibration* **243**(3), 2001, 441–459; and by A.H. Benade and M.I. Ibsi, *Journal of the Acoustic Society of America* **81** (4), 1987, 1152–1167.

There are a number of approaches to determine the acoustic impedance experimentally. The most straight-forward scheme requires 2 Sensors. A microphone to determine pressure, and an anemometer to measure volume flow. Instead of the anemometer a couple of microphones could be used that returns a signal proportional to the volume flow at a point half way between the two microphones. Sometimes the absolute value of the impedance is not needed. For example, if the resonance frequencies need to be determined, we need to find the extreme values of the impedance as function of frequency. Thus a signal is required that is proportional to the impedance. A number of methods employ a feedback loop to maintain a constant volume flow; then the pressure signal is proportional to the impedance.

Benade and Ibsi (citation see above) in great detail discuss an impedance probe that is easily realized with a piezo disc and a small electret microphone. The piezo disc is controlled by a function generator in such a way that a constant volume flow results without the need for a feedback loop. It is such an impedance probe that we employ for this experiment.

The reason this works is because the impedance of the piezo disc generally is much greater than the impedance of the pipe to be studied. This is equivalent to driving a current through a low-resistance load with a power supply with a much higher internal resistance than that of the load. Thus even with the load resistance changing, the current through the load remains constant as long $R_{Load} \ll R_{Power\ Supply}$ at all times. The piezo disc itself has a resonance, but typically that is above the frequencies of interest of the acoustic system. For example, the piezo we are using for this experiment has a resonance frequency near 6 kHz; the frequencies of interest for pipes or musical instruments under study typically are below 3 kHz.

Figure 3 shows the piezo and the microphone and views of the assembled probe. The piezo is a *Kobitone* piezo transducer (Mouser Electronics Part No. 256-PB012). The pressure detector is a *Kobitone* electret condenser microphone (Mouser Electronics Part No. EM2200) with a 2.2 k Ω output impedance and an operating voltage of 2 V. The microphone is only 6 mm in diameter and is mounted in hole drilled in the side of the coupler 10 mm away from the piezo disk. The probe itself is connected to the system under study, e.g. a cylindrical PVC pipe, the barrel of a clarinet, or the mouthpiece of a trombone.

Figure 4 is the circuit diagram of the impedance probe. Op-amp 741, R_1 , R_2 , and C_2 form an integrator that integrates the function generator signal and feeds it to the piezo. Since the function generator operates at constant amplitude, it would

generate a volume velocity that increases with frequency when fed to the piezo. Feeding the integrated function generator signal to the piezo results in a signal that produces a constant volume velocity in the tube. The feedback RC component is chosen for the integrator to have a low-f cutoff below 50 Hz.

The microphone signal is amplified by an AC-coupled 2-stage op-amp amplifier (type 747) bringing the signal into the 0–5 V working range of the digitizer. We are using a *National Instruments NI-USB 6008* with a maximum sampling frequency of 10 kHz. This allows digitizing waveforms of up to 5 kHz, which for our purposes is sufficient. If higher frequencies need to be sampled digitizer with sampling rates greater than 10 kHz must be used.

The open end of the impedance probe is easily attached to a schedule 40 $\frac{3}{4}$ " PVC pipe, and it can also be attached to $\frac{1}{2}$ " PVC pipes with a reducing adapter. Moreover, the impedance probe is easily adapted to fit the barrel joint of a B-flat clarinet or a trumpet or trombone mouthpiece and thus is suited for measurements on real instruments.

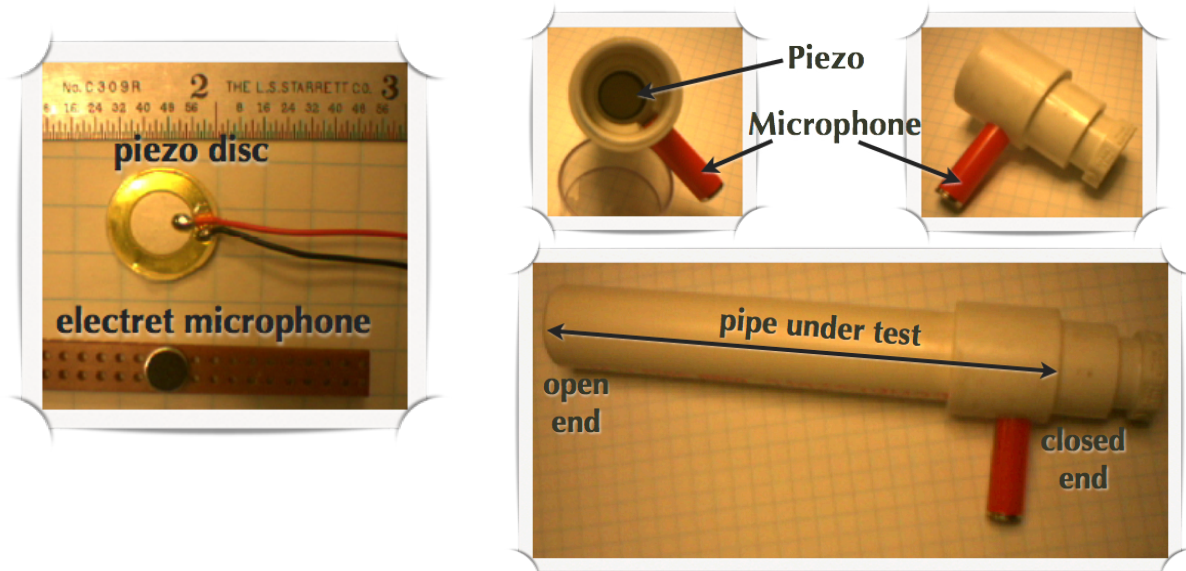
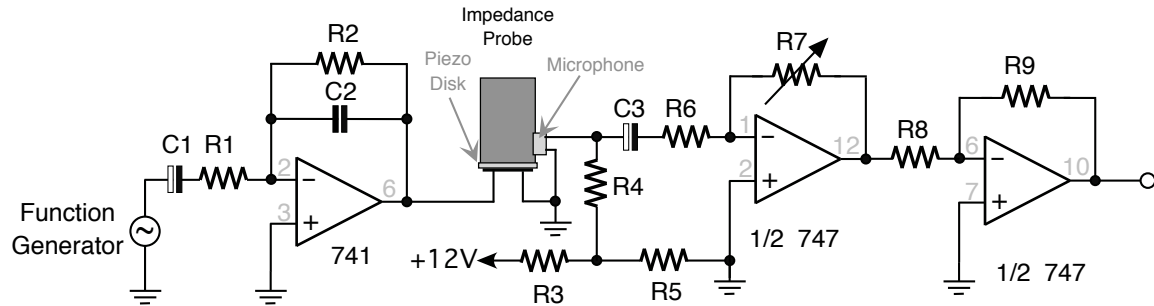

Fig. 3: The impedance probe for this experiment. The left photograph shows the piezo disc and the electret microphone used for the probe. The grid is a quarter inch square. The top-right two photographs show how the disc and the microphone are mounted in a short PVC tube. Microphone and piezo should be at the same plane but for practical reasons are about 10 mm apart. The microphone is installed at the end of a $\frac{1}{8}$ " audio connector. Connection to the piezo disc are made with an $\frac{1}{8}$ " audio plug. The lower-right photograph shows how the probe is mounted to a pipe under test. The probe represents a closed end, while the other end of the pipe is open.



R1 = 1k Ω	R4 = 2.2k Ω	R7 = 100k Ω (20-turn pot)	C1 = 1 μ F
R2 = 10M Ω	R5 = 1k Ω	R8 = 1.5k Ω	C2 = 56nF
R3 = 4.7k Ω	R6 = 1k Ω	R9 = 100k Ω	C3 = 1 μ F

Fig. 4: The circuit for this experiment. Op-amp 741 is the integrator that controls the piezo to generate a constant volume flow. The microphone signal is amplified by a 2-stage amplifier (747) with variable gain (R_7). Resistors R_3 and R_5 form a voltage divider to supply the needed voltage for the FET internal to the microphone.

Figure 5 shows the entire system with the impedance probe connected to the mouthpiece of a trombone. The integrator and microphone amplifier are in the small black box below the probe. The oscilloscope is used as a visual check, and below it sits the function generator. It is set up to produce a sine output of approx. 1 V_{rms} . A computer controls the frequency of the function generator, and a typical sweep is from 100 Hz to 3000 Hz in steps of 1 to 5 Hz. An A/D converter digitizes the output signal of the microphone amplifier and saves the microphone signal vs. frequency for later analysis. The A/D converter samples the microphone signal at 10 ksamples/s for a duration of 10 periods and determines the rms-amplitude of the signal.

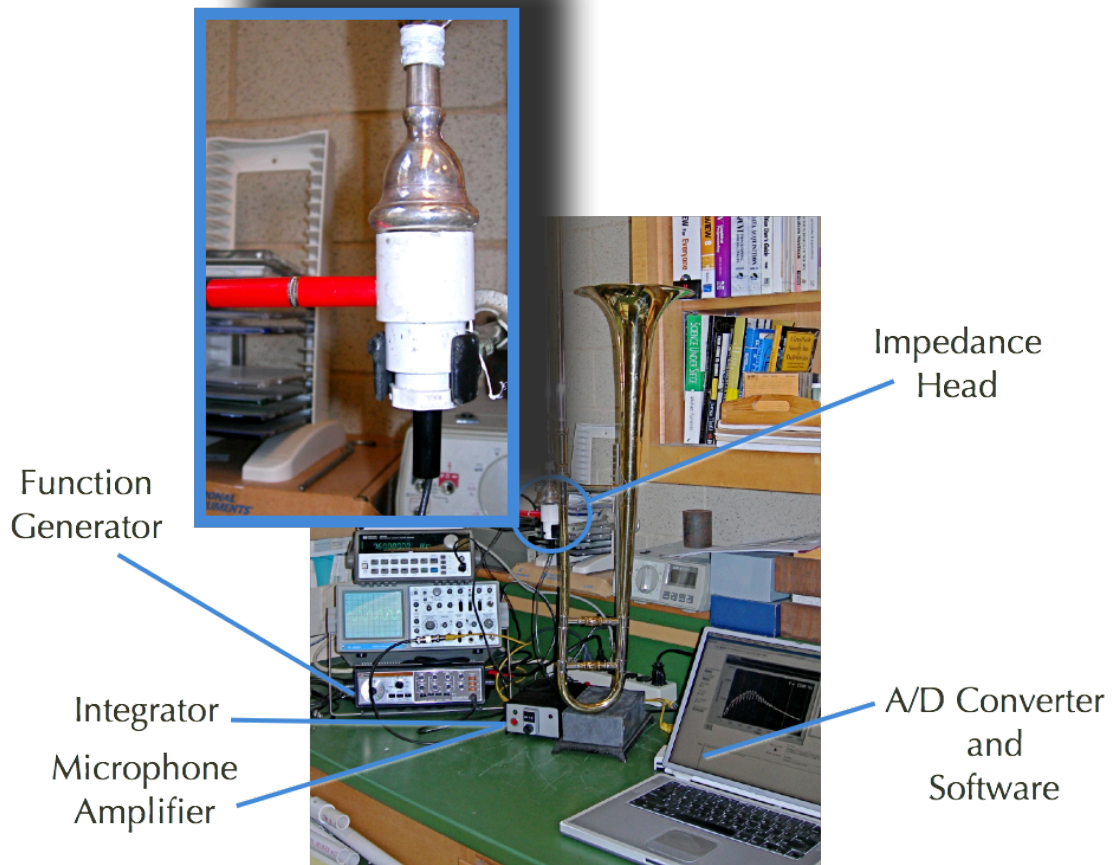

Fig. 5: The impedance probe and the associated electronics. The inset shows the probe mounted to the mouthpiece of a trombone.